

DT fluid cooler

AERO-X COIL TECHNOLOGY • HIGHER DRY OPERATION FLEXIBILITY

MARLEY® 



DT fluid cooler

INDUCED-DRAFT • CLOSED-CIRCUIT

Higher Performance. Higher Dry Switchpoint.

An induced-draft, coil only closed-circuit cooling tower, the Marley DT Fluid Cooler with Aero-X™ coil technology provides dry operation flexibility that fill/coil hybrid coolers cannot.

Aero-X Coil Technology Maximizes Thermal Capacity Per Coil Row*

The lowest air-side pressure drop (up to 10% more airflow at the same fan kW) and higher heat rejection capacity per coil row – benefits realized with the DT Fluid Cooler's Aero-X coil technology – provide opportunities to reduce equipment size and/or lower energy consumption, while maintaining the dry operation flexibility that coil only closed-circuit coolers are known for.

Higher Dry Switch Point – Up To 5.6°C + Higher*

Whether the motivation for seasonal dry operation is to reduce site water usage, minimize water treatment costs or simplify operation in freezing conditions, higher dry switch point temperatures enable achievement of those objectives a larger portion of the year. With up to 5.6°C + higher dry switch point, the DT Fluid Cooler may enable up to 15-20% incremental annual hours in dry mode. Annual water savings per cooling kW of 2585 liter/kW and €8.65/kW are achievable in many areas, depending on climate conditions. Optional finned coils further enhance dry operation capability at higher ambient temperatures.

*vs other conventional *coil only* evaporative fluid coolers



Lower Fluid Pressure Drop – Up To 30%

Reduced pumping energy requirements compared to the previous generation positively impact system operating cost and energy consumption.

Broad Product Selection

Choose from DT models in a wide range of sizes and layouts to meet your specific cooling requirements.

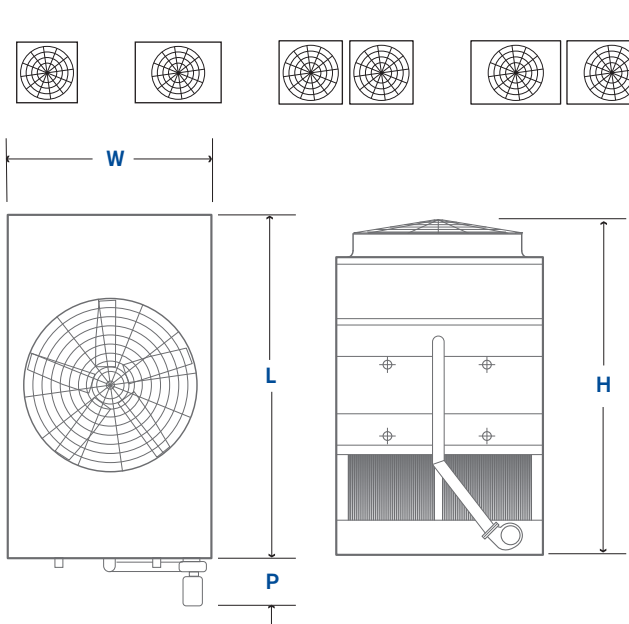

Models	L	W	P	H*
DTW8509	2743	2591	610	3759 – 4750
DTW8512	3658	2591	610	3886 – 4877
DTW1012	3683	3023	660	4343 – 5690
DTW1212	3683	3632	660	4928 – 5969
DTW1018	5537	3048	660	4343 – 5690
DTW1218	5537	3658	660	5055 – 6096

*Single cell heights shown, height increases for multiple cell models.

Value – Added Construction Details

MARLEY GEAREDUCER DRIVE

Genuine Marley mechanical system offers low maintenance costs and reliable performance with 5-year warranty. Belt drive optional.

CLOG-RESISTANT SPRAY SYSTEM

Large orifice spray nozzles help prevent debris build-up and clogging.

TRIPLE-PASS AIR INLET LOUVERS

Removable louvers incorporate three changes in direction to control splash out and sunlight exposure to limit algae growth.

Marley Reliability

Heavy-duty construction, galvanized and stainless steel material options, high-performance design and our five-year mechanical warranty ensure consistent cooling over a wide range of closed-circuit cooling applications.



IS THE MARLEY DT RIGHT FOR YOUR APPLICATION?



Find out at spxcooling.com/coolspec

ADDITIONAL DT FLUID COOLER INFORMATION

For further information about the DT Fluid Cooler – including engineering schematics, data, layout requirements and more – download at spxcooling.com



Engineering Data and Specifications

OTHER SPX COOLING PRODUCTS

SPX Cooling offers a full line of industry leading products – with unmatched support and innovation designed to help you get the most out of your cooling process. Take a look at these and other cooling products at spxcooling.com.



Marley MH Fluid Cooler



Marley LW Fluid Cooler



Recold JW Fluid Cooler



Marley NC Cooling Tower

SPX COOLING TECHNOLOGIES UK LTD

3 KNIGHTSBRIDGE PARK, WAINWRIGHT ROAD
WORCESTER WR4 9FA UK
44 1905 750 270 | ct.fap.emea@spx.com
spxcooling.com

uk_DT-22 | ISSUED 12/2022

©2016-2022 SPX COOLING TECH, LLC | ALL RIGHTS RESERVED

In the interest of technological progress, all products are subject to design and/or material change without notice.

